

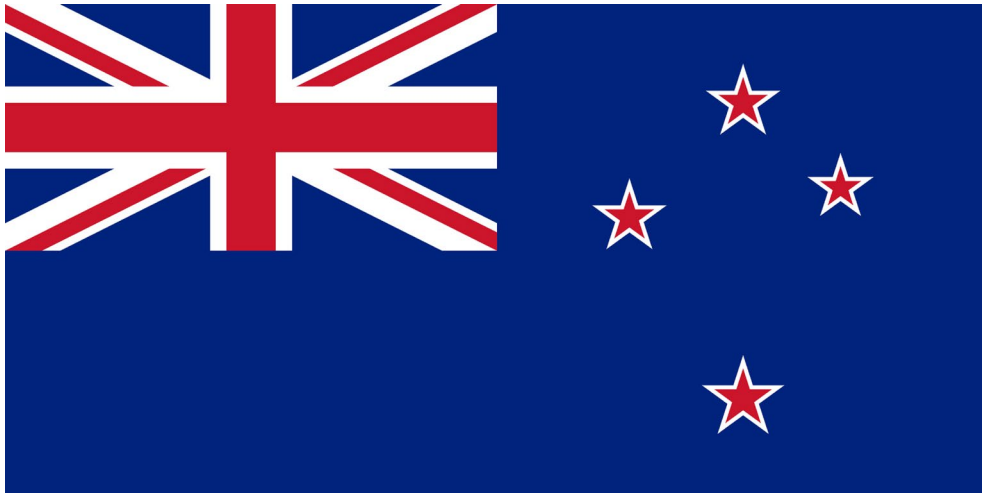

The Leon Morel Catalogue of Medallic Commemoratives of New Zealand up to 1940:

The 1890s



Chapter Editors: Martin Purdy, Jason Gray, Rodney Hall, and Hamish MacMaster

RNSNZ © 2020 - 2024

New Series (2022) Version 1. Last Updated: 2024-Mar-26

ISBN 978-1-99-110860-9

The Leon Morel Catalogue of Medallic Commemoratives of New Zealand up to 1940
The 1890s

ISBN

- 1 978-1-99-110860-9 (April 2024)
- 2 978-1-99-110861-6
- 3 978-1-99-110862-3
- 4 978-1-99-110863-0
- 5 978-1-99-110864-7

Martin Purdy FRNSNZ
Jason Gray
Rodney Hall
Hamish MacMaster FRNSNZ

Copyright © RNSNZ and the contributing editors, 2024

This work is freely distributable in electronic form and is not intended for sale or resale, either electronically or in hard copy. Please acknowledge the RNSNZ when sharing.

Download the latest version from
www.RNSNZ.org.nz/collector-info/catalogues

Royal Numismatic Society of New Zealand Inc.
PO Box 2023
Wellington 6140
New Zealand

Autobiographical Note



Leon with members of the "Starlets" coin club in 1966 (NZ Numismatic Journal no. 42)

My introduction to numismatics was at school when I swapped a box of marbles for WW1 coins. This small group of coins fascinated me and led me to visit the Canterbury Museum's large collection many times.

Fortunately a custodian suggested I contact Ernie Dale who was Chairman of a Society who could help me. He certainly did and I joined the Canterbury Branch of the RNSNZ and enjoyed many years in the company of informative speakers who widened my knowledge. I am forever grateful to the members of the Canterbury society.

The introduction of decimal currency in 1967 resulted in a surge in sales of New Zealand sterling coins at inflated prices, which led me to advertise price lists at what I considered more sensible levels.

New Zealand medallions were plentiful and, in 1950, with the issue of the Canterbury Centennial medal, I started collecting medallions in earnest which eventually led to the issue of a small catalogue in 1976, and later, as new items were found, a much expanded and illustrated second edition (1996) and a supplement (2000).

I also purchased a small, lovely collection of Edward VIII Coronation medallions, which grew into a very large collection. Many friendships resulted, including Richard Lobel of Coincraft, who has an amazing collection.

Autobiographical Note

Banknotes became an interest when I discovered the Reserve Bank of New Zealand would sell notes direct to collectors, a great service which has sadly been discontinued.

We retired to Melbourne, where our four sons resided, in 2000. So I packed my accumulation into 120 special containers which Customs officials were interested in but released them when they realised it was my private collection.

I am delighted that the team will update “Medallic Commemoratives New Zealand 1865-1940”.

My congratulations and appreciation.

Leon G Morel FRNSNZ (2016)



2006 anniversary event, at which Leon Morel (left) was the longest-standing RNSNZ member (joined 1950) and Ray Staal (right) the longest-standing WCC member present (joined 1966)

Note by the compilers (2020): Leon gave his agreement to our updating his catalogue to include more recent discoveries during his visit to the RNSNZ Convention in 2014. Work began almost immediately on digitising the text of his 1996 Catalogue and 2000 Supplement, as well as logging new discoveries and gathering photos of existing items. This activity has continued in the background ever since, though it has only been with the upheavals to normal work routines brought about by Covid-19 that we have had the opportunity to start putting it into its final shape.

Leon died in late 2019 at the age of 87, and we are saddened not only by the loss of someone who put such a huge effort into documenting and promoting New Zealand commemorative medals, but also by the fact that he did not live to see the release of the revised 3rd edition of his magnum opus.

Contents

Autobiographical Note	3
Contents	5
Introduction.....	7
Acknowledgements.....	9
Latest Additions	15
Amendments & Updates to 1996/2000 Edition	17
Commemorative Medals – 1890s.....	19
List of Makers & Manufacturers.....	91
Rarity Scale	93
About the Authors	95
The End.....	100

Introduction

The Leon Morel Catalogue of Medallic Commemoratives of New Zealand up to 1940:

The 1890s

Martin Purdy FRNSNZ
Jason Gray
Rodney Hall
Hamish MacMaster FRNSNZ

ISBN 978-1-99-110860-9

This is part of a projected multi-volume series updating Leon Morel's Catalogue of Medallic Commemoratives of New Zealand, 1865-1940 (1996) and the Supplement published in 2000. This new edition marks a departure from previous RNSNZ catalogue projects in that it is being released electronically in the first instance, and in sections. In this way, parts of the book can be published as they become ready and can also be regularly updated as new information becomes available.

The various sections of the catalogue will ultimately cover the whole of NZ's medallic history from the earliest issues associated with this country through to the Centennial events of 1940. More recent issues, from 1940 (not Centennial-related) to date, are being covered by a companion series, "New Zealand Commemorative Medals since 1940, New Series (2022)", also being published in parts and in electronic form.

Because these publications are being released as searchable PDFs, the previous Index of Legends has now been dispensed with as unnecessary.

Acknowledgements

Special thanks to the late Leon Morel for entrusting us with this project and supplying much original reference material.

Thanks to the many dealers and collectors who have made illustrations available, including Tony Grant, Phil Horne, Jim Noble, Jim Johnson, Ross and Angie Kidd, Craig Kitchen, Don MacNeill, and many others whom we have approached with specific requests since beginning this project in 2014. Special thanks also to the late Malcolm Johnson (Australia) for making available his research into oddball NZ items. It would not have been possible without their generous assistance.

Version no.: 1, April 2024

**Please advise the authors of any new discoveries, or any errors or omissions detected.
Contact email: martin_lists@yahoo.com**

Bibliography

NZ Medals:

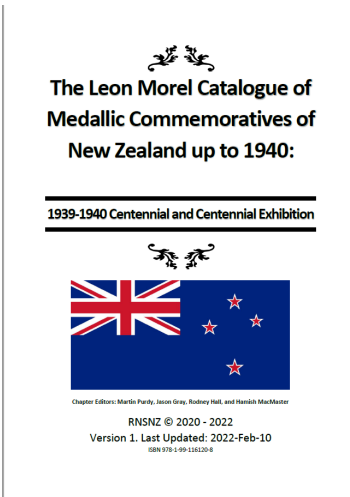

Purdy M, Gray J,
Hall R, MacMaster H

Medallic
Commemoratives of
New Zealand
Up To 1940
(New series, 2022)
© RNSNZ 2022
PDFs by chapter:

[www.RNSNZ.org/
collector-
info/catalogues](http://www.RNSNZ.org/collector-info/catalogues)



Morel L G

Medallic
Commemoratives
of New Zealand
1865-1940
(Supplement to
2nd edition)

© LGM 2000

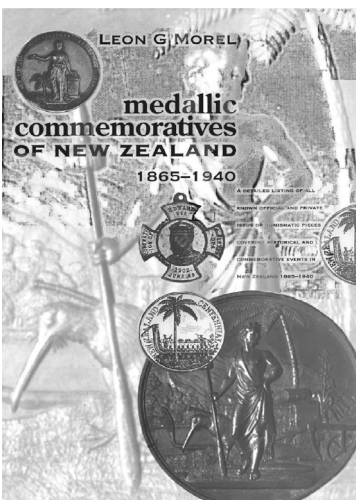

Morel L G

Medallic
Commemorative
of New Zealand
1865-1940
(2nd edition)

© LGM 1996



Morel L G

Medallic
Commemorative
of New Zealand
1865-1940
(1st edition)

© LGM 1976

New Zealand Commemorative Medals – 1890s

Bibliography

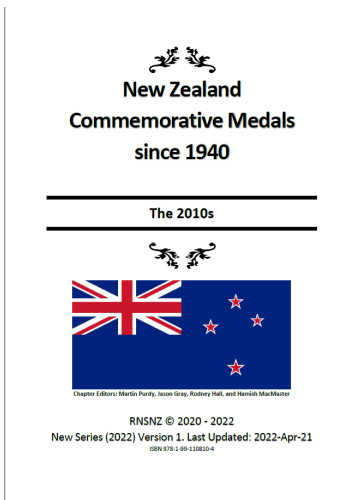

Purdy M, Gray J,
Hall R, MacMaster H

New Zealand
Commemorative
Medals Since 1940
(New series, 2022)

© RNSNZ 2022
PDFs by chapter:

[www.RNSNZ.org/
collector-
info/catalogues](http://www.RNSNZ.org/collector-info/catalogues)

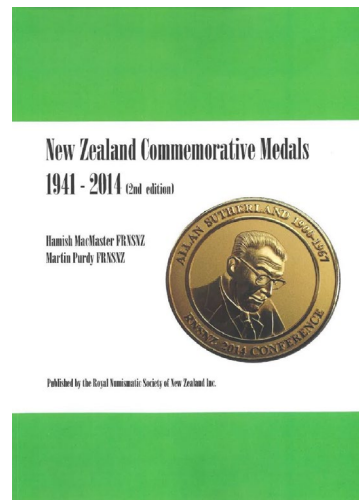

MacMaster H &
Purdy M

New Zealand
Commemorative
Medals 1941-2014
(2nd edition)

© RNSNZ 2014

ISBN
978-0-473-28731-3

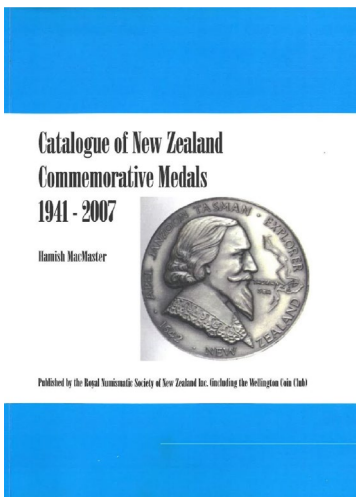

MacMaster H

New Zealand
Commemorative
Medals 1941-2007
(1st edition)

© RNSNZ 2007

ISBN
978-0-473-15585-8

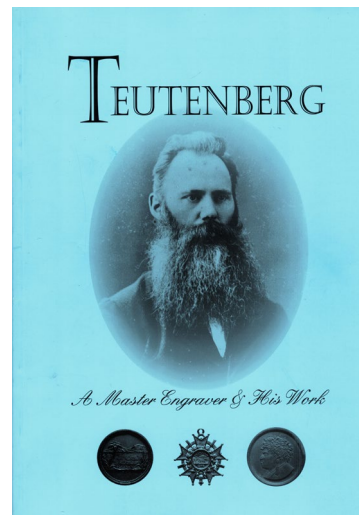

Cresswell JCM,
Duncan JB

Teutenberg, A Master
Engraver & His Work

© The authors, 2007

ISBN 0-473 07251-3

Other NZ:

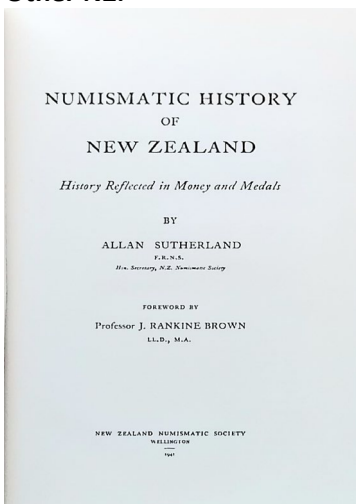

Sutherland A

Numismatic History
of New Zealand

History Reflected in
Money and Medals

© NZNS 1941



Thornton J

The John Bertrand™
New Zealand Coin &
Banknote Catalogue
2024

© John Bertrand 2024

ISBN
978-0-473-70716-3

New Zealand Commemorative Medals – 1890s

Bibliography

International:

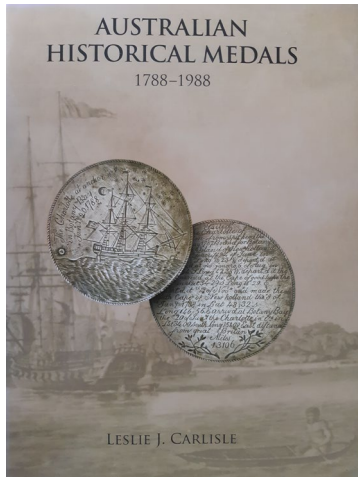

Carlisle L
 Australian
 Commemorative
 Medals 1788-1988

© L.J. Carlisle 2008
 ISBN
 978-0-98040-615-3

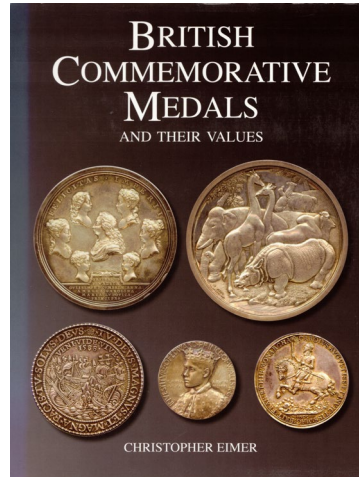

Eimer C
 British
 Commemorative
 Medals and Their
 Values

© Christopher Eimer
 2010
 ISBN
 978-1-907427-06-0

Serials:

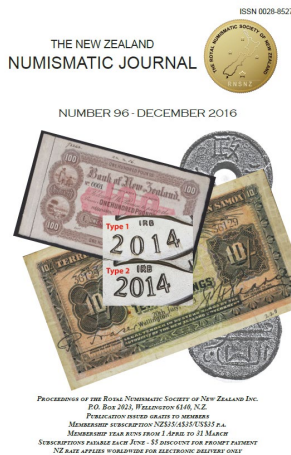

New Zealand
 Numismatic Journal

© RNSNZ 1947-
 ISSN 0028-8527

Royal Numismatic Society of New Zealand Inc
 P O Box 2023, WELLINGTON 6140, NEW ZEALAND
 E-mail: Secretary@RNSNZ.org.nz
 Website: www.RNSNZ.org.nz or www.RNSNZ.com
 Issue 73 Editor: David Galt

NEWSLETTER MAY 2017

COMING SOCIETY MEETINGS

RNSNZ Programme 2017		
Wednesday 26 April	St Andrew's 7.30pm	Wayne Newish "The Wellington Hoard Find" - Hear why the UK hoard discovery was one of the most significant recent numismatic events
Wednesday 31 May	St Andrew's 7.30pm	Martin Purdy with Rodney Hall - "A show-and-tell on 'ornithine money'"
Wednesday 28 June	St Andrew's Meeting Room 2 - upstairs, not our usual room. 7.30pm	Members' talks. Everyone has something to share that they know about - we look forward to your talk or "show and tell" of up to 5 minutes.
Friday 14 - Monday 17 July	Quality Hotel, Farnell, Auckland	Decimal 50 Conference. Celebrate the 50 th anniversary of decimal currency in Auckland with the NSA and RNSNZ's joint conference. See inside for details or find the brochure and registration form at www.RNSNZ.org.nz .
Wednesday 26 July	St Andrew's 7.30pm	Don't delay - register now. AGM. This is scheduled after the Auckland Conference this year, to allow time for preparation of accounts
Wednesday 30 August	St Andrew's 7.30pm	RNSNZ annual auction. Carl Leyby and Flemming Sorenson.
Wednesday 27 September	St Andrew's 7.30pm	Coins and banknote records will be brought from the Archives for viewing. See their updated website at www.koehnstage.co.nz

Newsletter of the
 Royal Numismatic
 Society of NZ Inc.

© RNSNZ 1984-
 (current series)

NUMISMATIC SOCIETY OF AUCKLAND INC
 P O Box 818, Auckland 1140, New Zealand

MINTMARK
 No 448 (OCT. 2021)
 Editor: ROBERT LOOSELEY

Some press work 30p entry

The Society's desired Annual General Meeting and Election of Officers will take place on Wednesday 13 October. Civil penalties as outlined in our did last year, commencing at 7.30pm. There is a maximum of two persons under the current restrictions, so those who wish to attend are asked to email the President as follows and receive directions. Once we have the confirmed attendees, we will ask for anyone else who would exceed the maximum, to make a prior arrangement with someone who will be present. They can then be relegated from the meeting to participate as a visitor, or make a further arrangement. The speaker will be Peter Dawson on the History of Clashes. Please bring a small 30p address in andrew@andrewclifford.com

IN THIS ISSUE
 Report of the September Meeting
 The Last Egyptian Pharaoh
 A Colonial American Banknote
 The Great Famine
 New Book - When Money Talks
 Dr J.L. Campbell and Frederick S28
 Royal New Zealand Numismatic Society

The Society meets on the second Wednesday of each month (except January) and publishes the Society's magazine MINTMARK 11 issues a year.

Subscription rates are:
 \$20 per annum from Sep. 1.

The magazine is printed on 100% recycled paper and is not necessarily done at the Society.
 To contact The Editor - jane@mintmark.org.nz or 09-481-0761/11-00

Mintmark
 Newsletter of the
 Numismatic Society
 of Auckland Inc.

© NSA 1959-

New Zealand Commemorative Medals – 1890s

Latest Additions

Amendments & Updates to 1996/2000 Edition

2 nd Edition	3 rd Edition	Detail
1890/2	1890/7	To group with new discoveries
1890/4	1890/3A	Grouping like with like, allowing for expansion
1890/5	1890/3B	
1890/6	1890/3C	
1897/3	1897/2A	Grouping like with like, allowing for expansion
1897/7	1897/6A	Grouping like with like, allowing for expansion
1897/10	1897/9A	Keeping common reverses together
1897/12	1897/11C	Keeping common reverses together
1897/15	1897/1A	Keeping common obverses together
1897/16	1897/6B	Keeping common obverses together
1897/17	1897/6C	
1898/3	1898/2A	Keeping common obverses together
1898/4	1898/2B	
1898/8	1898/20	Moved to keep Exhibition items together and leave space possible new discoveries after 1898/10
1898-99/3	1898-99/2A	Grouping like with like, allowing for expansion
1898-99/7	1898-99/4A	Keeping common obverses together
1898-99/8	1898-99/4B	Rev shared with 1898-99/4A
1898-99/9	1898-99/4C	
1899-1900/2	1899-1900/1A	Keeping common obverses together
1899-1900/8	1899-1900/7A	Keeping common obverses together
1899-1900/9	1899-1900/7B	
1900/16	1899-1900/10	Shows both dates – moved to keep with others

Commemorative Medals – 1890s

NEW ZEALAND AND SOUTH SEAS EXHIBITION OF 1889-1890

The Exhibition opened on 26 November 1889 on a site of 12½ acres belonging to the Dunedin Harbour Board. The intention of the Exhibition was to encourage closer ties and promote relations with Australasian colonies and South Pacific Islands and also to commemorate the jubilee of British sovereignty over New Zealand. A special Government grant of £10,000 paid for certain buildings and defrayed transportation costs for items borrowed from British Art Galleries. The Exhibition closed on 19 April 1890 and had attracted 625,478 visitors which enabled the guarantee company, which had been formed through the sale of 15,000 £1 shares, after paying all expenses, to have a surplus of £600.

1890/1



Diameter: 19 mm,
pierced
Metal: Silver, Brass/Gilt
Rarity: R6, R6



[1890/1.1]

Obverse: View of exhibition building. Like 1889-90/2 but NEW ZEALAND & SOUTH SEAS around above and EXHIBITION /1890 in exergue

Reverse: Eiffel Tower; 1000 / HI at L. FEET / GH at R. -> TOUR EIFFEL <- around above (like 1889-90/5)

Versions: 1890/1.1 Silver
1890/1.2 Brass or gilt



[1890/1.2]



[No. 1890/2 has been retired]

FIFTIETH ANNIVERSARY OF COLONY OF NEW ZEALAND 1890

1890/3



Diameter: 23.25 mm,
ornamental loop
suspension,
no suspension, pierced

Metal: Gold, Silver, Gilt,
Bronze

Rarity: R5, R3, R4, R4

Maker: S. Kohn



[1890/3.1]

Obverse: Wellington Harbour view with port facilities, steamship and canoe. Inscr around above IN COMMEMORATION / OF / THE FIFTIETH and in exergue ANNIVERSARY / OF THE / COLONY . 1890 (last line curved). In minute letters on exergual line S KOHN. Note: T of THE in top segment below O of COMMEMORATION; H of THE in exergue between E and R of ANNIVERSARY

Reverse: Wellington Harbour view with sailing ship and canoe. "RD" 1 at bottom left. Inscr around above WELLINGTON / .N.Z. and in exergue JANUARY 22ND / . 1840 . Note: sun's ray to Z

Versions:

1890/3.1	Gold, loop
1890/3.2.1	Silver, no suspension
1890/3.2.2	Silver, suspension
1890/3.2.3	Silver, pierced
1890/3.3	Gilt
1890/3.4	Bronze



[1890/3.2.1]



Commemorative Medals – 1890s



[1890/3.2.2]



[illustration unavailable]

[1890/3.2.3]

[illustration unavailable]

[illustration unavailable]

[1890/3.3]

[illustration unavailable]

[illustration unavailable]

[1890/3.4]

[illustration unavailable]

1890/3A
(1890/4)

[illustration unavailable]	Diameter: 23.25 mm, loop suspension, no suspension Metal: Gold, Silver, Bronze Rarity: R4, R4, R4 Maker: S. Kohn	[illustration unavailable]
----------------------------	---	----------------------------

[1890/3A.1]

Obverse: Like 1890/3 but first row to S; T of THE in upper segment below C of
 COMMEMORATION, H of THE in exergue under R
 Reverse: Like 1890/3 but rays differ; ray below Z and another to dot after Z
 Versions: 1890/3A.1 Gold
 1890/3A.2 Silver, loop
 1890/3A.3 Bronze, no loop



[1890/3A.2]



[1890/3A.3]



Commemorative Medals – 1890s



1890/3B
(1890/5)



Diameter: 23.25 mm,
loop suspension

Metal: Silver
Rarity: R7

Obverse: Like 1890/3A but first row to left leg of R; C of COMMEMORATION touches or almost touches T of THE

Reverse: Like 1890/3 but no "RD" 1, 2



1890/3C
(1890/6)



Diameter: 23.25 mm
Metal: Silver, Lead
Rarity: R7, R7

[1890/3C.1]

Obverse: Similar to 1890/3 but ships and building higher up (more sea in foreground); inscr around above IN COMMEMORATION / OF THE and in exergue 50TH ANNIVERSARY / OF / THE COLONY. Note: date 18 90 in low relief, split either side of OF

Rev: Like 1890/3B but without .N.Z.

Versions: 1890/3C.1 Silver
1890/3C.2 Lead



[1890/3C.2]



[Nos. 1890/4-1890/6 have been retired]

**NEW ZEALAND JUBILEE 1890
DUNEDIN EXHIBITION POULTRY PIGEON CANARY
CAGE BIRD & DOG SOCIETY**



1890/7
(1890/2)

Diameter: 35 mm
Metal: Silver
Rarity: R7



Obverse: Exhibition building in centre; EXHIBITION / 1890 below. Inscr around DUNEDIN POULTRY PIGEON CANARY CAGE BIRD & DOG SOCIETY +

Reverse: Inscr SOCIETY'S / EXHIBITION SHOWS / FIRST PRIZE / IN CLASS No. [xx] / AWARDED TO / [xxx]



1890/7A
(-)

Diameter: 28.5 mm
Metal: Silver
Rarity: R7



Obverse: Exhibition building in centre; EXHIBITION / 1890 below. Inscr around DUNEDIN POULTRY PIGEON CANARY CAGE BIRD & DOG SOCIETY ✪

Reverse: Inscr SOCIETY'S / EXHIBITION SHOWS / [xxx] PRIZE / IN CLASS No. [xx] / AWARDED TO / [xxx]

Note: "FIRST" or "SECOND" prize in line 3 and Class number in line 4 engraved by hand – both observed on this smaller version

**NEW ZEALAND JUBILEE 1890
AUCKLAND POULTRY PIGEON CANARY CAGE BIRD & DOG SOCIETY**



1890/8

(-)

Diameter: 28 mm,
loop suspension
Metal: Gold, Silver, Copper
Rarity: R7, R6, R7
Maker: A. Teutenberg



[1890/8.1]¹

Obverse: Two birds facing each other on ground line in centre; AT in small letters below ground line at L. 1840 TO 1890 in space below. Inscr around above IN COMMEMORATION OF THE NEW ZEALAND JUBILEE and around below .1890.

Reverse: Shield-shaped panel for engraving. AT in small letters at L below. Dog to R in open curved frame below, caged birds to L and R. Curved inscr above AUCKLAND POULTRY PIGEON CAGE BIRD & DOG SOCIETY / FIRST PRIZE / AWARDED TO; inscr around all AUCKLAND POULTRY PIGEON CAGE BIRD & DOG SOCIETY

Reference: Cresswell & Duncan, Teutenberg (Plate XXI, item N4, description as per N5)

Versions: 1890/2A.1 Gold
1890/2A.2 Silver
1890/2A.3 Copper



[1890/8.2]



¹ Image credits: Auckland Museum, Creative Commons licence, accessed 14/2/24

Commemorative Medals – 1890s



[1890/8.3]

1890/8A
(-)

Diameter: 28 mm,
loop suspension

Metal: Copper

Rarity: R7

Maker: A. Teutenberg

Obverse: Two birds on ground line in centre. 1840 TO 1890 below. Inscr around above IN COMMEMORATION OF THE NEW ZEALAND JUBILEE and around below .1890.

Reverse: Shield-shaped panel for engraving. Birds in suspended cages to L and R. Inscr above 2ND PRIZE / AWARDED TO; inscr around all AUCKLAND POULTRY PIGEON CAGE BIRD & DOG SOCIETY. AT in small letters at base

Reference: Cresswell & Duncan, Teutenberg (Plate XXI, item N6)



1890/8B
(-)

Diameter: 28 mm,
loop suspension
Metal: Silver, Bronze
Rarity: R7
Maker: A. Teutenberg

[1890/8B.1]



[Note: Indicative illustration
based on common die type]

[Note: Indicative illustration
based on common die type]

Obverse: As 1890/8

Reverse: Small cock and hen and AUCKLAND POULTRY, PIGEON, CAGE BIRD AND DOG SOCIETY. AWARDED TO ... CLASS ... CHAMPION PRIZE with spaces for engraving (*description from Cresswell & Duncan*)

Reference: Cresswell & Duncan, Teutenberg (Plate XXI, item N4 (description only))

Versions: 1890/8B.1 CHAMPION PRIZE, silver
1890/8B.2 FIRST PRIZE, silver
1890/8B.3 SECOND PRIZE, bronze

[illustration unavailable]

[1890/8B.2]

[illustration unavailable]

[illustration unavailable]

[1890/8B.3]

[illustration unavailable]

WEST COAST EXHIBITION 1893-94

No details about this Exhibition are known other than those gleaned from these medals and the brass award disc, and newspaper snippets mentioning the Exhibition in passing.

1893-94/1

(-)



Diameter: 41 mm,
loop suspension,
no suspension
Metal: Gold (9 ct?), Silver
Rarity: R7, R7

[1893-94/1.1]



Obverse: Closed wreath of conjoined fern fronds. Engraved inscr inside N.Z / WEST COAST / EXHIBITION / 1893-94 with decorative elements in between

Rev: All details in field engraved: AWARDED in ribbon / TO / [name] / - FOR - / [detail in 2-3 lines]

Versions: 1893-94/1.1 Gold (probably 9 ct), 25.8 g, loop suspension

1893-94/1.2 Silver, no piercing or loop

Note: Stock medal with rope circle inside rim. Minor differences in detail between silver and gold versions, e.g. down arrow below dates on silver. Reference to a silver medal awarded to a W. Ferrier has also been found online (Timaru Herald, 30 June 1894)



[1893-94/1.2]





1893-94/2

(-)

Diameter: 34.5 mm
 Metal: Brass (hollow, in two parts)
 Weight: 9.06 g (combined)
 Rarity: R6



[1893-94/2, outer faces]

Obverse: Closed wreath with bow. Inscr in centre N.Z / WEST COAST / EXHIBITION above diamond-shaped divider; 1893-94 below

Rev: Detail similar to 1893-94/1 but all details stamped: AWARDED in scroll / AHLFELD BROS & Co. / FOR / PIANO; A. WIESNER & Co. in scroll around below

Note: All detail on outer faces incuse; detail visible in relief and reversed on inner faces. *Note that these brass items are **not** medals per se but are normally found impressed into the inner lid of Wiesner pianos (one observed on TradeMe in December 2023). Their inclusion here is for information in cases in which they are found in isolation, as in the examples illustrated. A pair described as “brass award disc” sold in Noble Numismatics Auction 102 (2013) for A\$90*



[1893-94/2, inner faces]



[Detail from piano lid. Image from TradeMe seller by permission]

WELLINGTON INDUSTRIAL EXHIBITION 1896-97

The Exhibition was opened by the Governor of New Zealand, Lord Glasgow, on 18 November 1896 and continued into January 1897. It was reported by early January 1897 that the exhibition had covered its costs.

	<p>1896/1 (-)</p> <p>Diameter: 26 mm, loop suspension</p> <p>Metal: Gold (18 ct?)</p> <p>Weight: 12.9 g</p> <p>Rarity: R7</p> <p>Maker: S. Kohn</p>	
<p>Obverse: Tree fern in centre with traction engine at L with wool bale and stamper battery; at R an industrial wheel behind a sheep and lamb, with a sheaf of wheat at far R. Inscr in ribbon around above INDUSTRIAL EXHIBITION; in exergue WELLINGTON / N.Z. / 1896 On ground line in small letters S. KOHN</p> <p>Reverse: Closed wreath with engraved inscr Eb BASS / COMPETITION / 1st PRIZE / WON BY / J. ABLETT</p> <p>Note: See Mintmark 275, September 2006</p>		

AUCKLAND EXHIBITION 1896-97

There seems to be some debate as to whether an exhibition was actually held in Auckland in 1896-97 at all, and whether this medal is in fact incorrectly dated and should instead refer to the 1898-99 event. Medals for that exhibition are listed elsewhere in this chapter. See Mintmark no. 275, September 2006, and also *Teutenberg, A Master Engraver and His Work* (Cresswell & Duncan 2007), item K4.

	<p>1896-97/1 (-)</p>	
	<p>Diameter: 33.5 mm, loop suspension Metal: Silvered copper, Gilt, Copper Rarity: R6, R6, R7 (specimen?) Maker: Designed and struck by Anton Teutenberg, Auckland [1896-97/1.1]</p>	
<p>Obverse: Crowned royal arms. A.T in small letters below motto. Inscr around above AUCKLAND EXHIBITION and dates 1896.7 around below</p>		
<p>Reverse: Open wreath; Inscr AWARDED / TO / with space below for engraving</p>		
<p>Versions: 1896-97/1.1 Silvered copper, loop 1896-97/1.2 Gilt, loop 1896-97/1.3 Copper, loop removed from known example</p>		
	<p>[1896-97/1.2]</p>	
	<p>[1896-97/1.3]</p>	

QUEEN VICTORIA'S DIAMOND JUBILEE OF REIGN 1897

1897/1



Diameter: 38 mm,
pierced, unpierced
Metal: Silver, Copper, White
Metal
Rarity: R6, R6, R5
Engraver: F. Bowcher
Maker: Spink, London



[1897/1.1]

Obverse: Bust of Queen Victoria (1819-1901; reigned 1837-1901) to L with small crown; inscr around above VICTORIA and around below QUEEN . AND . EMPRESS. In field to L of effigy TO / COMMEM / ORATE / THE 60TH / YEAR and in field to R OF HER / MAJESTY'S / REIGN. In minute letters below bust F. BOWCHER. F.

Reverse: Shield containing cross and scales in centre; NEW ZEALAND in scroll below; smaller crowned UK shield above. Inscr around left GOD BLESS and around right OUR QUEEN; all in a wreath interrupted by a circle at the 9:00 and 3:00 positions, each containing the numerals 60. Below wreath in small letters inside lower rim SPINK LONDON

Note: Struck by Spink London, engraved by F Bowcher

Versions: 1897/1.1 Silver, unpierced
1897/1.2 Copper, unpierced
1897/1.3 White metal, pierced



[1897/1.2]



[1897/1.3]



**QUEEN VICTORIA JUBILEE & CAMBRIDGE PRIZE MEDAL
YOUNG PEOPLES INDUSTRIAL EXHIBITION 1897**



1897/1A
(1897/15)

Diameter: 33.5 mm
Metal: Gilt, White Metal
Rarity: R6, R6
Maker: Spink



[1897/1A.1]

Obverse: Like 1897/1

Reverse: PRIZE MEDAL (curved) / *- / CAMBRIDGE / ❖ N.Z. ❖ / 1897 in open wreath; outside wreath inscr YOUNG PEOPLE'S around at L, INDUSTRIAL EXHIBITION around at R; below wreath in small letters inside lower rim SPINK & SON, LONDON

Note: See article by Kevin Mills in NZNJ Vol. 17 no. 1 (64), November 1985. A silver version is reported but unconfirmed

Versions: 1897/1A.1 Gilt (123 issued)
1897/1A.2 White metal (102 issued)



[1897/1A.2]



QUEEN VICTORIA'S DIAMOND JUBILEE OF REIGN 1897

1897/2

Diameter: 23.5 mm,
loop suspension,
no suspension

[illustration unavailable]

Metal: Gold, Silver, Gilt,
Copper

[illustration unavailable]

Rarity: R4, R3, R3, R2

Maker: S. Kohn, Wellington

[1897/2.1]

Obverse: Queen Victoria receiving the news of the death of William IV and her own accession, with the Archbishop of Canterbury (standing) and the Lord Chamberlain (kneeling); cf retrospective painting of this scene by Mary Gow (1851-1929)² Inscr on ribbon above THE KING IS DEAD, LONG LIVE THE QUEEN; in exergue JUNE 20 1837. In minute letters at right on exergual line S KOHN

Reverse: Bust of Queen Victoria, crowned and veiled, to L in wreath of roses, shamrocks, thistles and leeks (to L) and ferns (to R); on ribbon at base of wreath JUNE 20. 1897. and above effigy ...N.Z... At base inscr RD. No. 82.

Note: Second D of DEAD noticeably out of alignment on this version; "RD. No. 82" sits below points of wreath stalks

Versions: 1897/2.1 Gold

1897/2.2 Silver (with or without suspension loop; thick (2.25 mm, no loop) and thin (2.00 mm, loop) versions noted; further research required)

1897/2.3 Gilt, no loop

1897/2.4 Copper, no loop

A partially silvered version has also been reported



[1897/2.2]



² <https://www.rct.uk/collection/452385/queen-victoria-receiving-the-news-of-the-death-of-william-iv-and-of-her-accession> (accessed on 4 December 2023)

Commemorative Medals – 1890s



[1897/2.3]

[1897/2.4]

1897/2A
(1897/3)

[illustration unavailable]

Diameter: 21 mm
 Thickness: 3.00 mm
 Metal: Silver, Bronze
 Rarity: R4, R2
 Maker: S. Kohn, Wellington

[illustration unavailable]

[1897/2A.1]

Obverse: Like 1897/2

Reverse: Like 1897/2

Note: Minor differences in font and wreath detail compared to 1897/2; "RD. No. 82" is in a plainer, narrower font and sits between points of wreath stalks

Versions: 1897/2A.1 Silver
 1897/2A.2 Copper

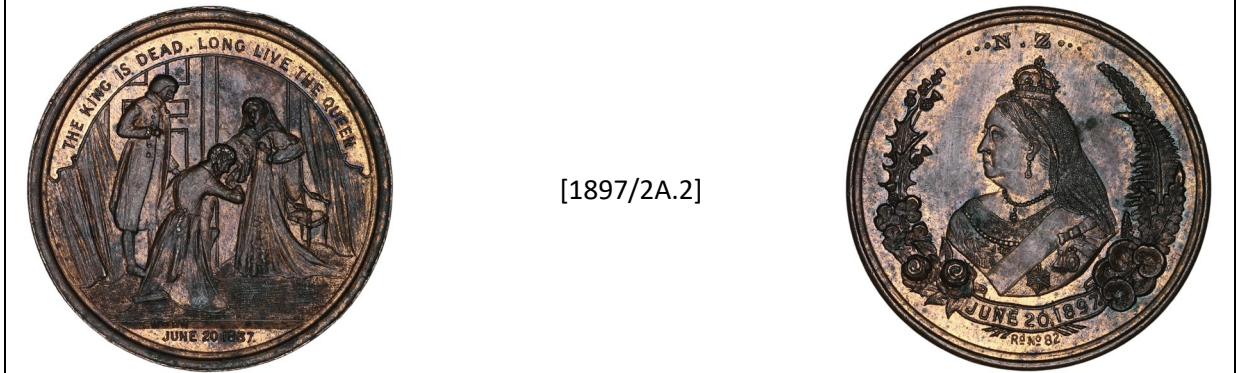

[1897/2A.2]

1897/2B

(1897/3)

[illustration unavailable]

Diameter: 21 mm
 Thickness: 2.50 mm
 Metal: Silver, Copper
 Rarity: R4, R2

[illustration unavailable]

[1897/2B.1]

Obverse: Like 1897/2
 Reverse: Like 1897/2A
 Versions: 1897/2B.1 Silver
 1897/2B.2 Copper



[1897/2B.2]



1897/2C

(1897/3)



Diameter: 21 mm,
 loop suspension,
 no suspension
 Thickness: 2.25 mm
 Metal: Gold, Silver, Bronze
 Rarity: R6, R4, R2

[1897/2C.1]



Obverse: Like 1897/2
 Reverse: Like 1897/2A
 Versions: 1897/2C.1 Gold, loop; note two weights reported for this thickness: 7.2 & 7.9 g
 1897/2C.2 Silver, no loop
 1897/2C.3 Copper, no loop

Commemorative Medals – 1890s



[1897/2C.2]

[1897/2C.3]

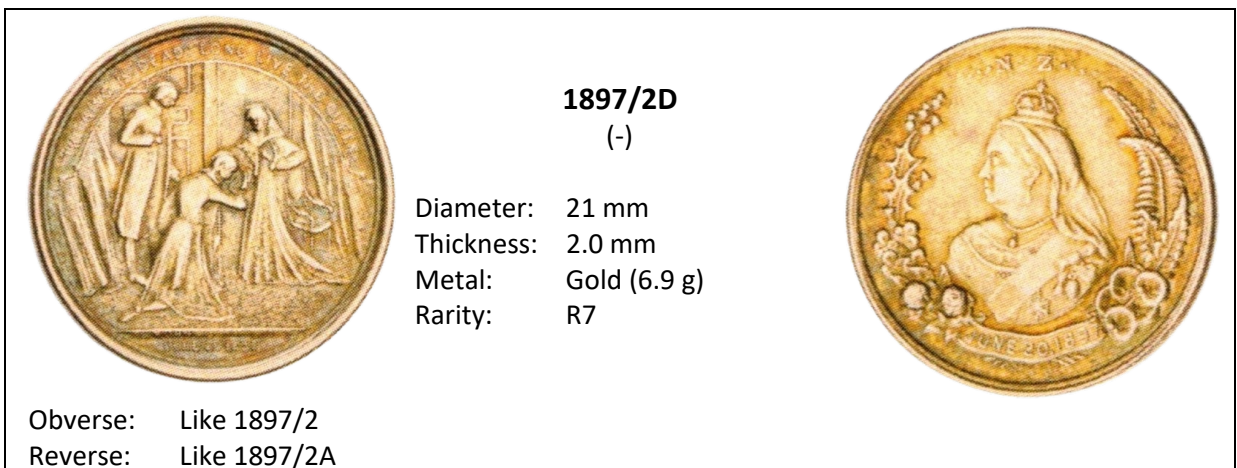

1897/2D
(-)

Diameter: 21 mm
 Thickness: 2.0 mm
 Metal: Gold (6.9 g)
 Rarity: R7

Obverse: Like 1897/2
 Reverse: Like 1897/2A

[No. 1897/3 has been retired]

1897/4



Diameter: 26 mm
pierced & unpierced
Metal: Silver, White metal
Rarity: R5, R4
Designer: H. Ross



[1897/4.1]

Obverse: Queen Victoria, crowned and veiled bust to L; 1837 in field at L, 1897 at R. Inscr around above VICTORIA and around below QUEEN & EMPRESS; in minute letters H ROSS below truncation

Reverse: Shield with cross and scales (cf. 1897/1); inscr around above in two curved lines TO COMMEMORATE THE SIXTIETH / YEAR OF H.M. REIGN; inscr around below NEW ZEALAND; wreath of crossed fern leaves with bow below

Versions: 1897/4.1 Silver, unpierced
1897/4.2 White metal, pierced



[1897/4.2]



1897/5



Diameter: 22 mm, milled edge,
loop suspension
Metal: Brass
Rarity: R2

Probably for general colonial use



Obverse: Bust of Queen Victoria to L, with small crown and veil; inscr around above IN COMMEMORATION OF H.M. DIAMOND JUBILEE and around below * 1897 *

Reverse: Two globes showing western and eastern hemispheres in centre; BRITISH EMPIRE in curved text below. Inscr above BARRATT / & CO'S and below SWEETS / ARE PURE

Note: For related issues see 1902/10-10B

1897/6



Diameter: 26 mm,
loop suspension
Metal: White metal
Rarity: R3



Obverse: Queen Victoria, crowned and veiled bust to L. Inscr around above IN COMMEMORATION OF QUEEN VICTORIA'S 60 YEARS REIGN and around below JUNE 1897.
Reverse: Crowned shield with scroll-like base and two flags above; scene with cabbage trees and toetoe with water behind and hills in the distance at R. Inscr in shield A SOUVENIR / OF THE / QUEEN'S / DIAMOND / JUBILEE.

1897/6A
(1897/7)



Diameter: 26 mm,
loop suspension
Metal: Silver
Rarity: R7



Obverse: Like 1897/6
Reverse: Like 1897/6 but engraved on shield BRUCE / CELEBRATIONS / 1ST PRIZE with decorative elements between lines
Note: This presumably refers to Bruce County, an administrative district in the South Island established in 1876 and disestablished in 1986. Its seat was in Milton, and it now forms part of the Clutha District

**QUEEN VICTORIA DIAMOND JUBILEE
ARTHUR STREET SCHOOL DUNEDIN 1897**



1897/6B
(1897/16)

Diameter: 26 mm,
loop suspension
Metal: White metal
Rarity: R6



Obverse: Like 1897/6

Reverse: School buildings and fenced grounds; inscr around above DIAMOND JUBILEE / ARTHUR ST / SCHOOL, and in exergue DUNEDIN

Note: Arthur Street School claims to be Dunedin's oldest, tracing its origins to classes given aboard the immigrant ship 'Phillip Laing' in 1848. Once established on land, it moved several times before taking up its present location in 1877 and acquiring its current name

**QUEEN VICTORIA DIAMOND JUBILEE
KAIKORAI SCHOOL (DUNEDIN) 1897**



1897/6C
(1897/17)

Diameter: 26 mm,
loop suspension
Metal: White metal
Rarity: R6



Obverse: Like 1897/6

Reverse: School buildings and grounds; inscr in ribbon above DIAMOND JUBILEE, and in exergue KAIKORAI / SCHOOL

Note: Kaikorai School was established in Roslyn, Dunedin, in 1869 and was first known as Linden School. It was renamed Kaikorai School in 1884 when the school was expanded and a larger building (depicted on the medal) was constructed

[No. 1897/7 has been retired]

1897/8



Diameter: 32 mm,
pierced
Metal: Gilt, Copper
Rarity: R4, R4
Maker: Stokes & Sons,
Melbourne



[1897/8.1]

Obverse: Obverse 1: Conjoined “young head” and “old head” effigies of Queen Victoria to L. Inscr around above QUEEN VICTORIA’S 60TH YEAR OF REIGN and around below + 1837 TO 1897 +; STOKES & SONS on bottom rim (often faint or illegible)

Key diagnostics for Obverse 1: Maltese crosses to L and R of dates, TO the same size as date digits

Reverse: Stock reverse with pattern of alternating triangles inside rim and blank field (cf 1887/4-8 and 1898-99/1)

Note: Also listed in Carlisle catalogue as an Australian issue (C#1897/75)

Versions: 1897/8.1 Gilt
1897/8.2 Copper



[1897/8.2]



1897/9



Diameter: 31 mm,
pierced
Metal: Gilt, Copper
Rarity: R4, R4
Maker: Stokes & Sons,
Melbourne



[1897/9.1]

Obverse: Obverse 2: Like 1897/8 but stars in place of crosses before and after date, STOKES & SONS on rim

Key diagnostics for Obverse 2: Stars to L and R of dates, TO much smaller than date digits

Reverse: HMS Victory to R, inscr VICTORY on hull; inscr around above QUEEN'S DIAMOND JUBILEE and around below * WESTPORT *

Versions: 1897/9.1 Gilt
1897/9.2 Copper



[1897/9.2]



1897/9A
(1897/10)



Diameter: 31 mm,
pierced
Metal: Gilt
Rarity: R4
Maker: Stokes & Sons,
Melbourne



Obverse: Like 1897/8 (Obverse 1)

Reverse: Like 1897/9

[No. 1897/10 has been retired]

1897/11



Diameter: 31 mm,
pierced, unpierced
Metal: Silver, Gilt, Copper
Rarity: R5, R3, R4
Maker: Stokes & Sons,
Melbourne



[1897/11.1]

Obverse: Like 1897/9 (Obverse 2)

Reverse: HMS Victory to R, inscr VICTORY on hull; inscr around above NELSON'S CELEBRATIONS and around below PALMAM QUI MERUIT FERAT

Note: STOKES AND SONS around bottom of obverse rim

Versions: 1897/11.1 Silver, unpierced
1897/11.2 Gilt, pierced
1897/11.3 Copper, pierced



[1897/11.2]



[1897/11.3]



1897/11A

[illustration unavailable]

Diameter: 31 mm,
pierced
Metal: Gilt, Copper
Rarity: R4, R4
Maker: Stokes & Sons,
Melbourne

[illustration unavailable]

[1897/11A.1]

Obverse: Like 1897/11 (Obverse 2) but no STOKES & SONS on rim
Reverse: Like 1897/11



[1897/11A.2]



1897/11B



Diameter: 31 mm,
pierced
Metal: Gilt
Rarity: R4
Maker: Stokes & Sons,
Melbourne



Obverse: Like 1897/11 (Obverse 2) but STOKES & SONS at top of rim
Reverse: Like 1897/11



1897/11C
(1897/12)

Diameter: 31 mm,
pierced & unpierced
Metal: Silver, Gilt, Copper
Rarity: R5, R3, R4
Maker: Stokes & Sons,
Melbourne



[1897/11C.1]

Obverse: Like 1897/11 but lozenges replace stars at dates (Obverse 3)
Reverse: Like 1897/11
Note: Incorrect obverse image in 1996 edition, corrected in 2000 Supplement
Versions: 1897/11C.1 Silver, unpierced
1897/11C.2 Gilt
1897/11C.3 Copper

[illustration unavailable]

[1897/11C.2]

[illustration unavailable]

[illustration unavailable]

[1897/11C.3]

[illustration unavailable]

[No. 1897/12 has been retired]

1897/13



Diameter: 33 mm,
pierced
Metal: White metal
Rarity: R6



Obverse: Crowned bust of Queen Victoria to L; inscr around at L VICTORIA and around at R REGINA; date 1897 below, all in open wreath of roses, shamrocks, thistles and leeks
Reverse: In centre inscr UNION / CLOTHING C^o with flower and leaf pattern above and below; inscr around above RECORD SUITS and around below . WELLINGTON .

1897/14



Diameter: 50 x 29 mm,
brooch style,
clasp back,
3 medallions, 1st
& 3rd 13.75 mm
Metal: Silver
Rarity: R7



Arrangement: Three medallions combined: centre medallion in wreath of conjoined fern fronds with crown above; smaller medallions to L and R
Obverse: In centre medallion "veiled head" bust of Queen Victoria to L; inscr around above VICTORIA'S 60TH ANNIVERSARY and below truncation 1837-1897; LH medallion shows canoe with hills/islands in the background; RH medallion shows a palm tree with hills/islands in the background
Reverse: Centre medallion shows incused image of reverse design (Queen only, no legends included); inscr STG SILVER incuse above. LH and RH medals blank apart from clasp attachments

[Nos. 1897/15-17 have been retired]

**MILITARY TOURNAMENT CELEBRATING
QUEEN VICTORIA'S DIAMOND JUBILEE 1897**

Jim Duncan in his book on the works of Anton Teutenberg records this medallion in silver but unawarded (M1897/18A), with a copper trial piece also known (M1897/18B).

The issued example shown here as M1897/18 was awarded for second place in a half-mile running event. We can assume medallions were also awarded for the winner and third place with the winner receiving a gold medallion and the third place getter a bronze or copper medallion. Normally the second place person would receive a silver medal; as the depicted medal for second place is gilded, this was probably done by the recipient at a later date.

The obverse die was re-used by the Numismatic Society of Auckland in 2009 for its 50th anniversary medals in gold, silver and bronze (see MP2009/3)

1897/18



Diameter: 41 x 28 mm,
loop suspension
Metal: Silver Gilt
Rarity: R6
Designer and Maker:
A. Teutenberg,
Auckland







Obverse: A shield, the top half divided to show a cyclist to left, on the left and two runners to left, on the right; military gunners and field gun in the lower half; all surmounted by a disc portraying Queen Victoria, draped head. There are flowers below the disc and it is draped with a ribbon inscribed 1837-1897. The ribbon continues at the bottom where it has the words VICTORIA'S GLORIOUS REIGN. The design is supported by a sailor on the left and a soldier on the right, and is surmounted by a crown flanked by a tree fern and a nikau palm. [*Description as per Cresswell & Duncan*]

Also A.T. in minute letters in circle containing the Queen's effigy, and A TEUTENBERG on suspender ring

Reverse: Engraved -> M . I . L . I . T . A . R . Y <- / TOURNAMENT / CELEBRATING / HER MAJESTY'S / DIAMOND JUBILEE / 1897 / HALF MILE / 2ND / D. TRANTER. On suspension ring above legend A.T. in minute letters

Note: Struck by A Teutenberg, Auckland

	1897/18A (-)	
	Diameter: 41 x 28 mm, loop suspension Metal: Silver Weight: 19.79 g Rarity: R7 Designer and Maker: A. Teutenberg, Auckland	
Obverse: As M1897/18		
Reverse: Struck legend MILITARY / TOURNAMENT / [small crown] / CELEBRATING / HER MAJESTY'S / DIAMOND JUBILEE (ornamental elements above and below last two lines)		
Reference: Cresswell & Duncan, Teutenberg (Plate 29, item P8)		

	1897/18B (-)	
	Diameter: 55 x 35 mm, irregular flan Metal: Copper Rarity: R7 Designer and Maker: A. Teutenberg, Auckland	
Obverse: Uniface trial strike of 1897/18 (or 18A) in copper		
Reverse: Blank, stamped 9ct [sic] three times		

1897/19

(-)



Diameter: 18 x 16 mm,
round with flattened
base (originally with
loop suspension)
Metal: Silver
Rarity: R7
Designer and Maker:
A. Teutenberg,
Auckland



Obverse: Veiled head effigy of Queen Victoria to L with sprigs behind. Inscr around above GOD SAVE THE QUEEN; A.T. below truncation
Reverse: Blank with beaded rim
Reference: Cresswell & Duncan, Plate 52, item X4 (noted "date and purpose unknown" but grouped here with other Diamond Jubilee items as the most likely option)

**VICTORIA'S DIAMOND JUBILEE OF REIGN 1897
AND OTAGO PROVINCE SILVER JUBILEE 1898**

1897-98/1



Diameter: 31 mm,
pierced
Metal: Gilt, Copper
Rarity: R2, R2



[1897-98/1.1 (all subtypes)]

- Obverse: Like 1897/11C (Obverse 3 with lozenges at dates)
 Reverse: Vessel 'John Wickliffe' in full sail to R. Inscr MARCH 1848 below. Inscr around above TO CELEBRATE THE JUBILEE OF OTAGO SETTLEMENT and around below . 1898 .
 Note: Varying thicknesses and weights of gilt version noted, with no design differences, as below
 Versions: 1897-98/1.1.1 Gilt, 2 mm thick, 11.75 g
 1897-98/1.1.2 Gilt, 2.3 mm thick, 12.60 g
 1897-98/1.1.3 Gilt, 2.4 mm thick, 12.98 g
 1897-98/1.2 Copper



[1897/1.2]



OTAGO PROVINCE SILVER JUBILEE 1898

1898/1



Diameter: 26 mm,
loop suspension
Metal: Silver, White metal
Rarity: R6, R4
Maker: J. Swan

[1898/1.1]



Obverse: Scroll in centre reading THE JUBILEE / OF / OTAGO / 1848-98. Ribbon above inscr A SOUVENIR; ship's masts and curved branch at L; city scene at R; five stars in field above. In minute letters below scroll SWAN

Reverse: Approaching vessel in harbour, viewed bow-on; hills behind. In foreground scene at water's edge with cabbage trees, flax and standing Māori figure holding spear. Canoe or rowing boat on water. Inscr around above ARRIVAL OF THE / JOHN / WICKLIFFE. Date 1848. in exergue

Versions: 1898/1.1 Silver
1898/1.2 White metal



[1898/1.2]



1898/2



Diameter: 22.5 mm,
pierced & unpierced
Metal: Silver, Gilt, Copper,
Brass
Rarity: R6, R5, R5, R5



[1898/2.1]

Obverse: Tattooed Māori male head to R. Inscr around at L OTAGO 1848 and around at R JUBILEE 1898. Colon (:) below truncation

Reverse: Inscr VITAM / EXCOLVERE / PER ARTES (THEY HAVE EMBELLISHED LIFE THROUGH THE ARTS) in wreath

Versions: 1898/2.1 Silver, pierced
1898/2.2 Gilt, pierced
1898/2.3 Copper
1898/2.4 Brass, pierced



[1898/2.2]



[illustration unavailable]

[1898/2.3]

[illustration unavailable]



[1898/2.4]



Commemorative Medals – 1890s



1898/2A

(1898/3)

Diameter: 22.5 mm,
pierced

Metal: Silver, Gilt

Rarity: R7, R7

[1898/2A.1]

Obverse: Obv: As 1898/2
Reverse: Like 1898/2 but plain field
Versions: 1898/2A.1 Silver
 1898/2A.2 Gilt

[1898/2A.2]

Commemorative Medals – 1890s



1898/2B
(1898/4)

Diameter: 22 mm,
pierced
Metal: Silver, Gilt, Aluminium
Rarity: R6, R6, R6



[1898/2B.1]

Obverse: Like 1898/2

Reverse: In toothed centre circle arms of New South Wales, with kangaroo and emu as bearers.
Inscr in outer circle around STRUCK AT EXHIBITION MINT . *

Versions: 1898/2B.1 Silver
1898/2B.2 Gilt
1898/2B.3 Aluminium

[illustration unavailable]

[1898/2B.2]



[illustration unavailable]



[1898/2B.3]



Commemorative Medals – 1890s

	<p>1898/2C (-)</p> <p>Diameter: 22 mm, pierced</p> <p>Metal: Gilt</p> <p>Rarity: R7</p>	
<p>Obverse: Like 1898/2B reverse</p> <p>Reverse: Like 1898/2</p> <p>Note: Mule of 1898/2B reverse and 1898/2 reverse</p>		

[Nos. 1898/3 and 1898/4 have been retired]

OTAGO JUBILEE EXHIBITION 1898

This exhibition was a small but successful one held during celebrations to mark the 50th Anniversary of the Province.

1898/5



Diameter: 38 mm
 Metal: Silver, Gilt, Bronze
 (bronze without and with loop)
 Rarity: R6, R5, R6, R6
 Maker: Moller, Dunedin



[1898/5.1]

Obverse: Conjoined heads of Rev. Thomas Burns (1796-1871) and William Cargill (1784-1860) to L. Inscr around above OTAGO JUBILEE INDUSTRIAL EXHIBITION and . MDCCCXCVIII . around below

Reverse: Open wreath; inscr AWARDED / TO with space for engraving in centre. In small letters inside rim at base MOLLER DUNEDIN

Note: A contemporary news report claimed that these medals were to be struck in gold (sic), silver and bronze (100 of each)

Versions: 1898/5.1 Silver
 1898/5.2 Gilt
 1898/5.3.1 Bronze, no loop
 1898/5.3.2 Bronze, loop

[illustration unavailable]

[1898/5.2]

[illustration unavailable]



[1898/5.3.1]



Commemorative Medals – 1890s

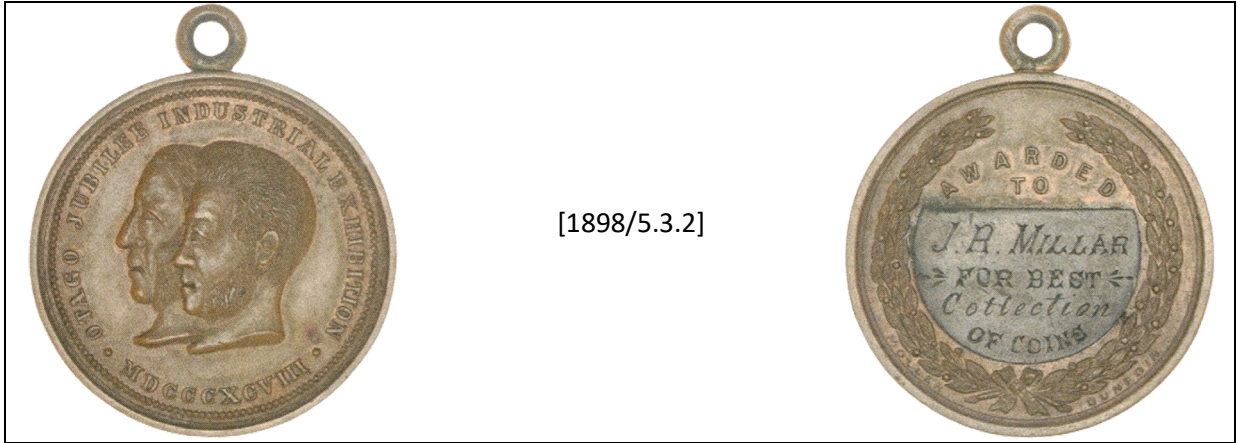

[1898/5.3.2]

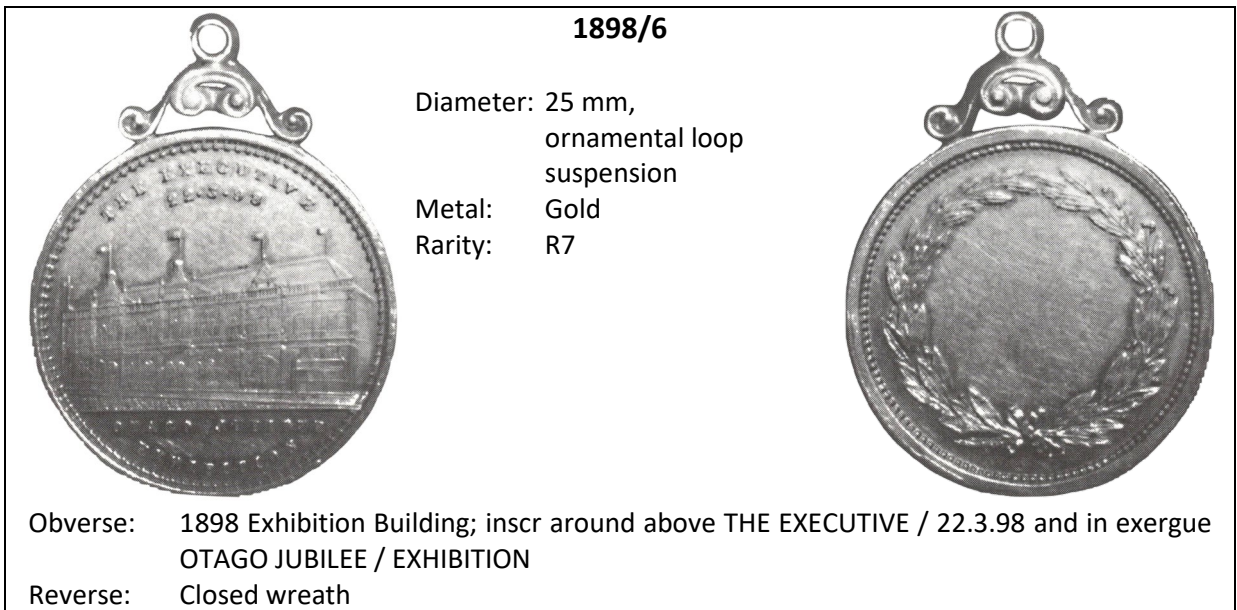

1898/6

Diameter: 25 mm,
ornamental loop
suspension
Metal: Gold
Rarity: R7

Obverse: 1898 Exhibition Building; inscr around above THE EXECUTIVE / 22.3.98 and in exergue OTAGO JUBILEE / EXHIBITION
Reverse: Closed wreath

1898/7

Diameter: 17 mm,
pierced, loop
suspension

[illustration unavailable]

Metal: Gold, Silver, Silvered,
Gilt, Brass

[illustration unavailable]

Rarity: R6, R4, R4, R5, R3

(1898/7.1)

Obverse: Exhibition building (cf. building illustrated on 1889-90 NZ & South Seas Exhibition issues); inscr around above OTAGO JUBILEE and in exergue 1898 / EXHIBITION

Reverse: In centre circle veiled head of Queen Victoria to L; inscr around STRUCK AT THE EXHIBITION MINT . . (note T of MINT under bust; cf. 1898-99/2)

Note: Silver version also noted in brooch between two examples of 1889-90/14, most likely a private concoction (1898/7A)

Versions:
1898/7.1 Gold
1898/7.2 Silver, loop
1898/7.3 Silvered, pierced
1898/7.4 Gilt, pierced
1898/7.5 Brass, pierced



[1898/7.2]



[1898/7.3]



Commemorative Medals – 1890s



[1898/7.4]

[1898/7.5]

1898/7A
(-)



Diameter: 38 x 17 mm,
with brooch clip

Metal: Silver

Rarity: R7?



Note: Silver version of 1898/7 formed into brooch, between two examples of 1889-90/14, most likely a private concoction

[No. 1898/8 has been retired]

Commemorative Medals – 1890s

1898/9



Diameter: 53 mm
 Thickness: 4.5 mm
 Metal: Lead
 Rarity: R6



Obverse: Inscr OTAGO / INDUSTRIAL / COMMEMORATION / MEDAL / 1848-1898
 Reverse: Inscr REID & GRAY / ESTABLISHED / 1858 / AGRICULTURAL / IMPLEMENT MAKERS

1898/10
(-)



Diameter: 36 mm (38 mm incl loop), cross-shaped with loop suspension
 Metal: Silver (tested 0.925)
 Rarity: R7



Obverse: Round medal with four attachments forming cross. Central “medal” component contains open wreath with space for engraving (this example engraved AB); on upper segment of cross, bar with inscr OTAGO S.S.; on left segment, bar inscr UNION; on right segment, bar inscr EXHIB'N; and on lower segment, bar inscr NOV 1898.
 Reverse: Blank for engraving. This example: TO / A. BUDD / CHOIR SECRETARY / SLIGHT MEMENTO / RECOGNITION / -> BY <- / COMMITTEE

[Nos. 1898/11-19 reserved for potential further exhibition discoveries]

**PRESBYTERIAN CHURCH OF OTAGO AND SOUTHLAND
GOLDEN JUBILEE 1898**



1898/20
(1898/8)

Diameter: 26.25 mm,
pierced & unpierced
Metal: White metal
Rarity: R4, R4
Maker: Spink & Son, London

[1898/20.1.1]



Obverse: In centre circle Rev. Thomas Burns (1796-1871), facing $\frac{3}{4}$ right. Inscr around above REV DR. BURNS THE FOUNDER OF THE PRESBYTERIAN CHURCH and around below . OF OTAGO & SOUTHLAND N.Z. 1848 .

Reverse: In centre circle a representation of the burning bush (Exodus 3:2), with ribbon below reading NEC TAMEN CONSUMERATUR (“And the bush was not consumed” – note: error for CONSUMEBATUR). In small letters around below SPINK & SON LONDON
In outer circle around above THIS MEDAL IS STRUCK TO COMMEMORATE and around below .THE JUBILEE OF THE CHURCH 1898.

Versions: 1898/20.1.1 Pierced
1898/20.1.2 Unpierced



[1898/20.1.2]



AUCKLAND INDUSTRIAL AND MINING EXHIBITION 1898-99

This exhibition was opened on 1 December 1898 on a five-acre site adjoining Government House. The exhibition had limited Government backing and a guarantee of £3,000 against possible loss. Promoted by the Auckland Chamber of Commerce, support from approx. 100 prominent citizens assisted in its opening. By the time it closed in February 1899, some 250,000 persons had viewed the exhibits.

1898-99/1



Diameter: 31 mm,
pierced
Metal: Gilt, Copper
Rarity: R2, R2
Maker: Stokes & Son,
Melbourne



[1898-99/1.1]

Obverse: Vessel in full sail to R (almost identical to that on 1897-98/1 but possibly intended to represent the 'Platina'). Inscr around above . AUCKLAND . and around below FOUNDED BY CAPT. HOBSON 1840

Reverse: Stock reverse with pattern of alternating triangles inside rim and blank field (cf. M1887/4-8, M1897/8). Inscr in centre COMMEMORATION / - MEDAL - / AUCKLAND / 1898-9; inscr around INDUSTRIAL & MINING EXHIBITION *

Versions: 1898-99/1.1 Gilt
1898-99/1.2 Copper



[1898-99/1.2]



1898-99/2

Diameter: 17 mm,
loop suspension,
pierced

[illustration unavailable]

Metal: *Gold, Silver, Gilt,
Silvered, Brass, Copper*

[illustration unavailable]

Rarity: *Exists?, R2, R2, R2, R2,
R2*

[1898-99/2.1]

Obverse: Exhibition building. Inscr around above INDUSTRIAL EXHIBITION and in exergue 1898.9 / . AUCKLAND . Note: Short flagpoles to I at left and level with N at right

Reverse: Like 1898/7 but T of MINT to right of bust. Most, possibly all, examples have a die crack between the T and I of EXHIBITION

- Versions:
- 1898-99/2.1 *Gold (reported but not confirmed)*
 - 1898-99/2.2 Silver, loop
 - 1898-99/2.3 Gilt, loop
 - 1898-99/2.4 Silvered
 - 1898-99/2.5 Brass, pierced
 - 1898-99/2.6 Copper



[1898-99/2.2]



[1898-99/2.3]



Commemorative Medals – 1890s

[illustration unavailable]

[1898-99/2.4]

[illustration unavailable]



[1898-99/2.5]



[illustration unavailable]

[1898-99/2.6]

[illustration unavailable]

	<p>1898-99/2A (1898-99/3)</p>	
	<p>Diameter: 17 mm, loop suspension, pierced Metal: Gold, Silver, Gilt, Silvered, Copper, Brass Rarity: R7, R2, R5, R5, R2, R2</p>	
	<p>[1898-99/2A.1]</p>	
<p>Obverse: Like 1898-99/2 but longer flagpoles reaching N and O Reverse: Like 1898-99/2, including die crack Versions: 1898-99/2A.1 Gold, loop 1898-99/2A.2.1 Silver, loop 1898-99/2A.2.2 Silver, pierced 1898-99/2A.3 Gilt, pierced 1898-99/2A.4 Silvered, pierced 1898-99/2A.5 Copper 1898-99/2A.6 Brass, loop</p>		
	<p>[1898-99/2A.2.1]</p>	
	<p>[1898-99/2A.2.2]</p>	

Commemorative Medals – 1890s



[1898-99/2A.3]



[1898-99/2A.4]



[illustration unavailable]

[1898-99/2A.5]



[illustration unavailable]



[1898-99/2A.6]



Commemorative Medals – 1890s

	<p>1898-99/2B (-)</p> <p>Diameter: 22.5 mm Metal: Silver Rarity: R7</p>	
<p>Obverse: Same as 1898-99/2A Reverse: Inscr N.Z. in open wreath, same as 1882/14</p>		

1898-99/4



Diameter: 22.5 mm,
pierced & unpierced
Metal: Silver, Gilt, Brass,
Aluminium
Rarity: R5, R5, R5, R6



[1898-99/4.1]

Obverse: Similar to 1898-99/2 but larger building and smaller lettering; dates now shown as 1898-9 (with dash not period)

Reverse: Closed wreath with space for engraving in centre

Versions: 1898-99/4.1 Silver, pierced
1898-99/4.2 Gilt
1898-99/4.3 Brass
1898-99/4.4 Aluminium, pierced

[illustration unavailable]

[1898-99/4.2]

[illustration unavailable]

[illustration unavailable]

[1898-99/4.3]

[illustration unavailable]



[1898-99/4.4]





1898-99/4A
(1898-99/7)

Diameter: 22.5 mm,
pierced
Metal: Silver, Copper, Gilt,
Brass, Aluminium
Rarity: R4, R4, R3, R4, R4



[1898-99/4A.1]

Obverse: Like 1898-99/4

Reverse: St George and Dragon (based on Pistrucci design) to R in centre circle; inscr around above STRUCK AT THE and around below EXHIB. MINT, with a star at each cardinal point; the whole in an irregular shield-shaped internal border (cf. 1906-07/20A)

Versions: 1898-99/4A.1 Silver
1898-99/4A.2 Copper
1898-99/4A.3 Gilt
1898-99/4A.4 Brass
1898-99/4A.5 Aluminium

[illustration unavailable]

[1898-99/4A.2]

[illustration unavailable]



[1898-99/4A.3]



Commemorative Medals – 1890s



[1898-99/4A.4]



[illustration unavailable]

[1898-99/4A.5]

[illustration unavailable]



1898-99/4B
(1898-99/8)

Diameter: 22.5 mm,
pierced
Metal: Silver
Rarity: R6



Obverse: Like 1898-99/4 reverse
Reverse: Like 1898-99/4A reverse



1898-99/4C

(1898-99/9)

Diameter: 22.5 mm,
pierced, loop
suspension

Metal: Silver, Gilt, Bronze

Rarity: R7, R5, R5



[1898-99/4C.1]

Obverse: Like 1898-99/4

Reverse: Queen Victoria, crowned and veiled effigy to L. Inscr around above AUCKLAND INDUSTRIAL & MINING EXHIBITION and below truncation 1898.9

Versions: 1898-99/4C.1 Silver, pierced

1898-99/4C.2 Gilt (loop; example illustrated has also been pierced and plugged)

1898-99/4C.3 Bronze



[1898-99/4C.2]



[illustration unavailable]

[1898-99/4C.3]

[illustration unavailable]

1898-99/5



Diameter: 48 mm
 Metal: Gold (18 ct), Bronze
 Weight: 96 g (gold version)
 Rarity: R7, R7
 Maker: A. Kohn



[1898-99/5.1]

Obverse: Exhibition buildings; inscr around above AUCKLAND EXHIBITION and around below 1898.9; in minute letters below building at left A. KOHN

Reverse: Open wreath with bow, field blank for engraving (illustrated example awarded to John Grey and Sons for Aerated Waters and Cordials, and is in original A. Kohn box)



Note: *This exhibition was funded by the Auckland Chamber of Commerce who were hardly in a position to give a 96 gram, 18 ct gold medal to every exhibitor who won a class medal. In fact I found a reference stating this: post the exhibition, the Exhibition Organisers invited gold medal certificate winners to the offices of the exhibition where: "medal (blanks) could be observed and prices ascertained". I guess the more wealthy you were the bigger the gold medal you could afford to buy. The larger one here was purchased by one Charles D. Grey, managing director of John Grey and Sons, who went on to become Mayor of Auckland for a term or two (depending on which reference book you read). [Comment by current owner]*

Versions: 1898-99/5.1 Gold
 1898-99/5.2 Bronze



[1898-99/5.2]



	<p>1898-99/5A (-)</p> <p>Diameter: 25.4 mm, loop suspension</p> <p>Metal: Gold (18 ct)</p> <p>Weight: 15 g</p> <p>Rarity: R7</p> <p>Maker: A. Kohn</p>	
<p>Obverse: Exhibition buildings; inscr around above AUCKLAND EXHIBITION and around below 1898.9; decorative element above date. In minute letters below building at left A. KOHN</p> <p>Reverse: Closed wreath with bow; field blank for engraving</p> <p>Note: <i>[This example] awarded to Carder Bros and Co., for Garden Furniture, Turf Rollers (among other things). Carder Brothers became part of "The Amalgamated Pipe and Brick Company" in Auckland around 1920. This is also in 18 ct gold and has a small suspension ring attached to the top. It weighs in at a more modest 15 grams. [Comment by current owner]</i></p>		

1898-99/6



Diameter: 29.5 mm,
pierced, unpierced
Metal: Gold, Silver, Gilt,
Copper, Brass,
Aluminium
Rarity: R7, R5, R5, R4, R5, R5
Maker: A. Kohn



[1898-99/6.1]

Obverse: Like 1898-99/5A

Reverse: Like 1898-99/5

Note: Similar to design of above medals but with much thicker rim (reverse rim engraved?)
Note also that the diameter quoted in Morel (1996) of 22.5 mm is probably an error

Versions: 1898-99/6.1 Gold (18 ct , 17.2 g), unpierced
1898-99/6.2 Silver
1898-99/6.3 Gilt
1898-99/6.4 Copper
1898-99/6.5 Brass
1898-99/6.6 Aluminium

[illustration unavailable]

[1898-99/6.2]

[illustration unavailable]

[illustration unavailable]

[1898-99/6.3]

[illustration unavailable]

Commemorative Medals – 1890s

[illustration unavailable]

[1898-99/6.4]

[illustration unavailable]

[illustration unavailable]

[1898-99/6.5]

[illustration unavailable]

[illustration unavailable]

[1898-99/6.6]

[illustration unavailable]

[Nos. 1898-99/7-9 have been retired]

SOUTH AFRICAN WAR 1899-1902

The war commenced in the 2nd week of October, 1899, when the Transvaal and Orange Free State Forces attacked British troops in the Cape Colony. The New Zealand Prime Minister, Richard Seddon, offered to the British Prime Minister, Joseph Chamberlain, 250 mounted rifles. Whilst being declined when it was originally made on 3 October, it was accepted on the commencement of hostilities. The first two contingents numbered between 200 and 220 volunteers from the trained Militia. These departed from New Zealand between 21 October 1899 and 20 January 1900. The Third and Fourth had no previous military training but were skilled marksmen and horsemen. These contingents were known as Rough Riders. Commencing with the Fifth contingent, the British Government paid all expenses of the New Zealand troops. The Fifth, Sixth and Seventh contingents numbered between 500 and 600 men, while the Eighth to the final contingent the Tenth, which left on 19 April 1902, numbered just over 1,000 men in each contingent. The total troops which departed New Zealand for the Boer War numbered 6,495, of whom 228 lost their lives and 166 were wounded during the 30 months of fighting.

1899-1900/1



Diameter: 22.5 mm,
loop suspension,
pierced
Metal: Silver, Silvered Copper,
Gilt, Copper
Rarity: R4, R7, R2, R2



[1899-1900/1.1]

Obverse: Queen Victoria, veiled head to L. Inscr around above BRITISH TRANSVAAL WAR
Reverse: In dotted circle, flag of the United Tribes of New Zealand with date 1899 below. Inscr around above SUCCESS TO NEW ZEALAND CONTINGENT and around below . 1900 .
Versions: 1899-1900/1.1 Silver, loop suspension
1899-1900/1.2 Silvered copper, pierced
1899-1900/1.3 Gilt, pierced
1899-1900/1.4 Copper, pierced



[1899-1900/1.2]



Commemorative Medals – 1890s



1899-1900/1A
(1899-1900/2)

[illustration unavailable]

Diameter: 22.5 mm,
pierced

Metal: Silver, Gilt, Bronze

Rarity: R3, R2, R2

[1899-1900/1A.1]



Obverse: Like 1899-1900/1

Reverse: Tattooed Māori head to R; inscr around at L SUCCESS TO NEW ZEALAND and around at R CONTINGENT 1899-1900

Versions: 1899-1900/1A.1 Silver
1899-1900/1A.2 Gilt
1899-1900/1A.3 Bronze



[1899-1900/1A.2]



[illustration unavailable]

[1899-1900/1A.3]

[illustration unavailable]

[No. 1899-1900/2 has been retired]

1899-1900/3



Diameter: 22.5 mm,
pierced
Metal: Silver, Silvered Copper,
Gilt, Bronze
Rarity: R5, R3, R3, R3
Maker: Stokes & Sons



[1899-1900/3.1]

Obverse: Queen Victoria, veiled head to L. Inscr around above BRITISH TRANSVAAL WAR; date at L * 1899 and below truncation 1900

Reverse: Mounted infantryman to L. Inscr around at L SUCCESS TO OUR NEW ZEALAND and around at R ROUGH RIDERS; dated 1900 in exergue

Note: This reverse with a different inscription ("GOOD LUCK TO AUSTRALIAN BUSHMENS CORPS") also used on an Australian issue (C1899-1900/6)

Versions: 1899-1900/3.1 Silver
1899-1900/3.2 Silvered Copper
1899-1900/3.3 Gilt, pierced
1899-1900/3.4 Bronze

[illustration unavailable]

[1899-1900/3.2]

[illustration unavailable]



[1899-1900/3.3]



Commemorative Medals – 1890s

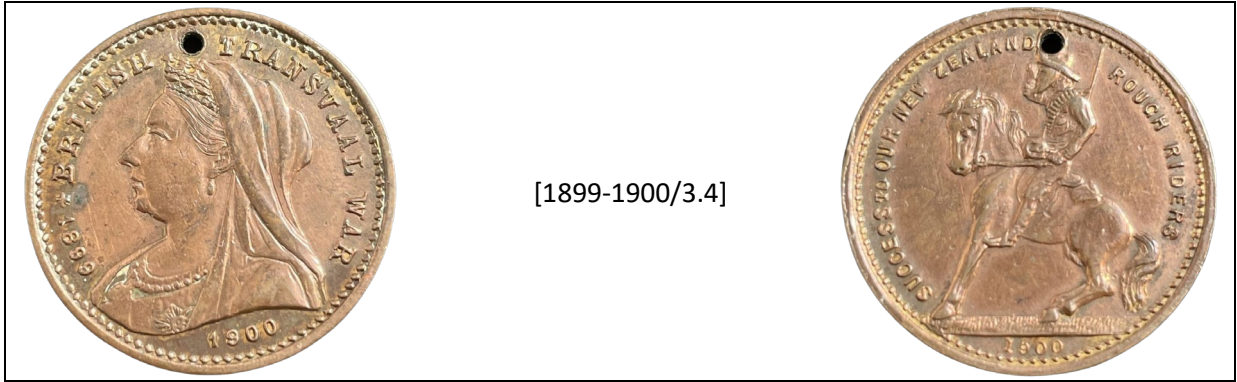

[1899-1900/3.4]

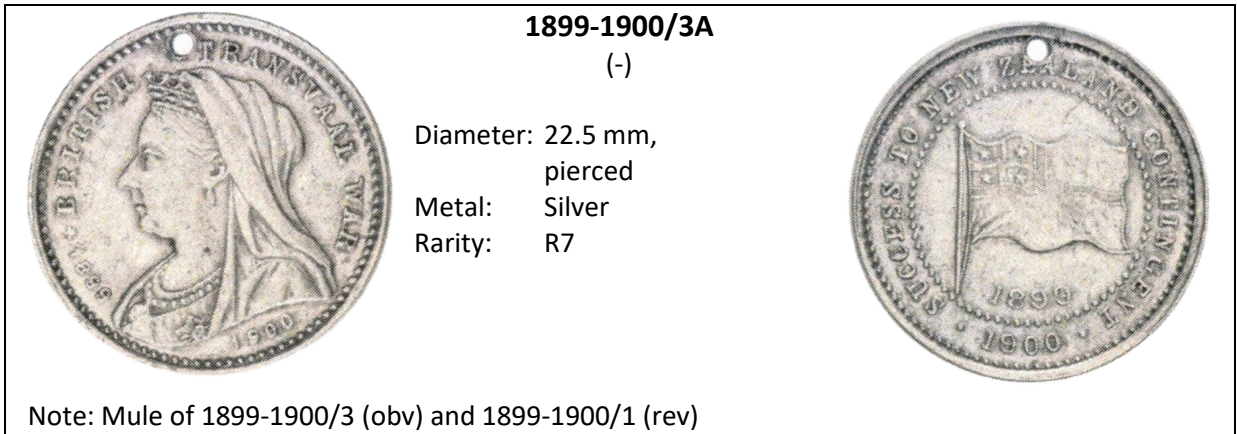

1899-1900/3A

(-)

Diameter: 22.5 mm,

pierced

Metal: Silver

Rarity: R7

Note: Mule of 1899-1900/3 (obv) and 1899-1900/1 (rev)

1899-1900/4

[illustration unavailable]	Diameter: 21 mm, loop suspension, no suspension Metal: Silver, Gilt, Bronze Rarity: R4, R4, R4	[illustration unavailable]
----------------------------	--	----------------------------

[1899-1900/4.1]

Obverse: Inscr in centre THE / DEPARTURE / OF THE / N.Z. CONTINGENTS / TO THE / TRANSVAAL; around above TO COMMEMORATE and around below 1899 . 1900

Reverse: Bust of Field Marshal Frederick Sleigh Roberts, 1st Earl Roberts (1832-1914) in uniform to L between fern fronds. Ribbon reading . KIA. TOA. AKE. AKE . around below. In minute letters inside bottom rim No. 114

Versions: 1899-1900/4.1 Gold
 1899-1900/4.2 Silver, loop
 1899-1900/4.3 Gilt, loop
 1899-1900/4.4 Bronze



[1899-1900/4.2]



[1899-1900/4.3]



Commemorative Medals – 1890s

[illustration unavailable]

[1899-1900/4.4]

[illustration unavailable]

1899-1900/5

Entry in 1996 edition showing Queen Victoria (obv) and Lord Roberts (rev)
deleted, confirmed as Australian issue

Flag is Australian, refer Carlisle listing C#1899-1900/9

1899-1900/6



Diameter: 22 mm,
pierced & unpierced
Metal: Silver, Copper, White
Metal
Rarity: R4, R4, R4



[1899-1900/6.1]

Obverse: Crossed flags (Union Jack and United Tribes of New Zealand); inscr around above BRITISH TRANSVAAL / WAR and around below 99 . 1900 .

Reverse: Horseshoe and other accoutrements in centre. Inscr around above SUCCESS TO NEW ZEALAND and around below + ROUGH RIDERS +

Versions: 1899-1900/6.1 Silver
1899-1900/6.2 Copper
1899-1900/6.3 White Metal

[illustration unavailable]

[1899-1900/6.2]

[illustration unavailable]

[illustration unavailable]

[1899-1900/6.3]

[illustration unavailable]

Commemorative Medals – 1890s



1899-1900/6A

(-)

Diameter: 22 mm,
pierced
Metal: Silver, Copper, White
Metal
Rarity: R7, R6, R7?



[1899-1900/6A.1]

Note: As 1899-1900/6 but dates read 89 - 1900 .

Versions: 1899-1900/6A.1 Silver
1899-1900/6A.2 Copper
1899-1900/6A.3 White Metal



[1899-1900/6A.2]



[1899-1900/6A.3]



1899-1900/7



Diameter: 22 mm,
pierced
Metal: Gilt, Copper
Rarity: R4, R4
Maker: J. Swan



[1899-1900/7.1]

Obverse: Queen Victoria, veiled head to L; inscr around above BRITISH TRANSVAAL WAR . 1899 – 1900 . In small letters below truncation SWAN. Tip of crown touches left leg of A

Reverse: Like 1899-1900/6

Versions: 1899-1900/7.1 Gilt
1899-1900/7.2 Copper



[1899-1900/7.2]



1899-1900/7A

(1899-1900/8)



Diameter: 22.5 mm,
pierced
Metal: Gilt, Copper, White
Metal
Rarity: R4, R4, R4
Maker: J. Swan



[1899-1900/7A.1]

Obverse: Like 1899-1900/7 but tip of crown between AA; curve of truncation above SWAN flatter than on 1899-1900/7; B of BRITISH and dot after 1900 closer to effigy

Reverse: Like 1899-1900/6

Versions: 1899-1900/7A.1 Gilt
1899-1900/7A.2 Copper
1899-1900/7A.3 White Metal



[1899-1900/7A.2]



[illustration unavailable]

[1899-1900/7A.3]

[illustration unavailable]

Commemorative Medals – 1890s

	1899-1900/7B (1899-1900/9)
	Diameter: 24 mm, pierced Metal: Brass Rarity: R6
Obverse: Like 1899-1900/7A Reverse: Blank	[illustration unavailable]

[Nos. 1899-1900/8 and 9 have been retired]

	<p>1899-1900/10 (1900/16)</p>	
	<p>Diameter: 31 x 20.5 mm, lozenge shaped, loop suspension</p> <p>Metal: Silver, Silvered copper, Gilt</p> <p>Rarity: R7, R7, R7</p>	
	<p>[1899-1900/10.1]</p>	
<p>Obverse: In centre inscr * / N.Z. / CONTINGENTS / SAILED / -.- / KIA / ORA / *; inscr along top sides 1ST 21.10.1899 2ND 20.1.1900 and along bottom right side 3RD 17.2.1900</p> <p>Reverse: In centre axe, horseshoe and riding crop / NZ flag / fern frond with two ribbons reading RANFURLY / GOVERNOR; N.Z. above. Inscr along top sides ROUGH RIDERS and along bottom sides BRITISH TRANSVAAL WAR; star in each angle</p> <p>Note: Loop is integral to flan, not an add-on</p> <p>Versions: 1899-1900/10.1 Silver 1899-1900/10.2 Silvered copper 1899-1900/10.3 Gilt</p>		
	<p>[1899-1900/10.2]</p>	
	<p>[1899-1900/10.3]</p>	

1899-1900/10A

(-)



Diameter: 31 x 20.5 mm,
lozenge shaped,
no loop
Metal: Silver, Silvered
copper, *Gilt*
Rarity: R7, R6, (-)



[1899-1900/10A.1]

Obverse: As 1899-1900/10

Reverse: As 1899-1900/10

Note: Examples examined appear to have been made without a loop, with no sign of one having been broken off

Versions: 1899-1900/10A.1 Silver
1899-1900/10A.2 Silvered copper
1899-1900/10A.3 Gilt *[existence unconfirmed]*



[1899-1900/10A.2]



[existence unconfirmed]

[1899-1900/10A.3]

[existence unconfirmed]

List of Makers & Manufacturers

Medallists and Manufacturers

<p>Frank Bowcher</p>	<p>English sculptor and medallist, 1864 – 1938. See https://victorianweb.org/sculpture/bowcher/index.html (accessed 13 December 2023)</p>
<p>Adolph Kohn Queen Street, Auckland</p>	<p>Jeweller in Christchurch, Whanganui and lastly Auckland; died 1910</p>
<p>Siegfried Kohn Wellington</p>	<p>Medallist (1854 – after 1902), brother of Adolph Kohn. Took over Kohn & Co. in 1885 and was listed as “jeweller, optician, watchmaker and importer of jewellery and silverware” in 1896. Produced 1885 NZIE medal, the series of Wellington Jubilee medalets in 1890 and the 1897 Diamond Jubilee medalets (1897/2, 2A). Business taken over by G.T. White of Wellington and Christchurch sometime after 1902. See NZNJ 81 (December 2003)</p>
<p>C. Moller & Sons Dunedin (Brandwell Moller) 24 McBride Street South Dunedin +64 3 477 6332 brandwell.moller@xtra.co.nz</p>	<p>Established in Dunedin in the 1860s. Subsequently part of Hanson & Berry in Auckland, then acquired by an engraving firm in Dunedin in 1980 and trading under the name Brandwell Moller Ltd</p>
<p>H. Ross</p>	<p>Designer of 1897/4</p>
<p>Spink & Son 67-69 Southampton Row Bloomsbury WC1B 4ET London +44 20 7563 4005 concierge@spink.com www.spink.com</p>	<p>Established in London in 1666. A major auction house and publisher, also responsible for numerous medal issues</p>

List of Makers & Manufacturers

<p>Stokes Melbourne, VIC, and Riverwood, NSW PO Box 779 Riverwood NSW 2210 Australia +61 2 8525 7676 sales@stokesbadges.com.au</p>	<p>Founded 1856. Prominent manufacturer responsible for producing many tradesmen's tokens and medals for Australia and New Zealand.</p> <p>Later Stokes & Martin, Thomas Stokes & Sons, and now Stokes Badges</p>
<p>John Swan & Co. Ltd Dunedin and Auckland</p> <p>366 Moray Place, Central Dunedin Dunedin 9016 +64 3 477 2064 orders@johnswan.co.nz www.johnswan.co.nz</p>	<p>Founded 1878. Auckland branch operated for 20 years in the early 20th century. Last family owner sold company to new owner in 2015</p>
<p>Anton Teutenberg</p>	<p>Born near Cologne in 1840 and settled in NZ in 1866. A prolific maker of medals, decorations, seals, etc. He retired during WW1 and his business was sold.</p> <p>The definitive reference work is Teutenberg, A Master Engraver & His Work, by John Cresswell and James Duncan (2007), ISBN 0-473-07251-3</p>

Rarity Scale

To assist the collector in determining the possibility of obtaining any of the listed commemorative pieces, a rarity scale has been included. This is based upon personal collectors and dealers combined knowledge.

No estimates of value have been included as this publication is intended as a numismatic record not a price catalogue. In some respects, it is unnecessary as collectors and dealers already have a market worth and appreciation of commemoratives and will pay accordingly.

As a general rule rarity does not automatically mean that a medallion is highly valuable. In numismatics, prices depend on additional factors to scarcity such as condition and demand. Also, handsome medallions commemorating events or occasions of importance can be worth more than equally or scarcer pieces issued for unimportant or obscure events. For example 1865/1 or 1872/1 both with a R5 rarity are more valuable than 1882/18 with a R6 rarity or 1906-07/39 with an even higher R7.

Also, price quotes quickly become outdated.

R1	very common	
R2	common	
R3	normal	
R4	scarce	
R5	rare	(estimated 11 to 25 known)
R6	very rare	(estimated 4 to 10 known)
R7	extremely rare	(estimated 1 to 3 known)

The rarity figures provided are the compilers' best estimates in each case and are not definitive. The editors would be interested to learn of any known mintage figures or confirmed known quantities that suggest any of the stated estimates should be changed.

About the Authors ...

Martin Purdy FRNSNZ



Martin arrived in New Zealand as a five-year-old in 1970 with a matchbox full of British coins that eventually formed the basis for his collection.

The discovery of coins with legends in foreign languages and different alphabets led him to a career as a translator, though he has remained an active collector and student of coins and medals for over 50 years.

A former President of both the Royal Numismatic Society of New Zealand (2003-2006) and the Wellington Coin Club (1989-1994), and Secretary of the RNSNZ (1990-1997), he was involved in editing and publishing the Society's Journal for over twenty-five years, becoming a Fellow of the Society in 2003.

Subsequently, he collaborated with Hamish MacMaster on larger-scale undertakings such as the two editions of the catalogue of post-1940 Commemorative Medals published in 2009 and 2014, and the first and second editions of the Catalogue of NZ Challenge Coins (2011, 2016). In collaboration with Rodney, he compiled and published a supplement to the 2nd edition in May 2019.

A new initiative is this chapter-by-chapter electronic publication of a third edition of Leon Morel's catalogue of pre-1940 medallic commemoratives, with an electronic third edition of the "MacMaster" post-1940 catalogue being prepared in parallel.

A keen vintage car enthusiast, Martin also edits Sphinx-NZ, the magazine of the Armstrong Siddeley Car Club in NZ.

Jason Gray



Jason started to take an interest in numismatics after being shown a 1993 kingfisher design \$2 coin by his grandfather as a teenager. But it was not until many years later that he started collecting coins himself, joining the Manawatu Numismatic Society in 2007. His interests extended to medals and tokens. However, his passion is in the small details of coin errors, and this is documented on his website coinerrors.nz.

Now Jason works on discovering, photographing, and cataloguing New Zealand coins, tokens, and commemorative medals, and has contributed to the medal and challenge coin catalogues in this series since 2014.

He is a keen kayak angler and loves going on adventures with the family.

Rodney Hall



Rodney was born in an England still gripped by food rationing. At 18 months, he travelled by plane (BOAC Argonaut) via the Middle East and Ceylon to Singapore (a three-day trip with flying only during daylight hours).

He spent the next 13 years overseas in Malaya, Singapore and finally on the island of Zanzibar in East Africa, and has fond memories of sea, sand, and sun on the beaches there, with boarding school just a plane, train, and bus ride away in Kenya.

It was during these years in East Africa that Rodney started collecting world coins, garnered by his father who travelled extensively around the world as a fisheries scientist.

After returning by ship (the P&O liner Chusan) via Cape Town to England, he could not wait to leave again, and in 1978 with a young family in tow emigrated to New Zealand.

Along with his interest in NZ challenge coins, Rodney also collects NZ Geocoins, NZ Pathtags and Philippine challenge coins, and is actively researching and gathering data for various electronic catalogues, including monthly online updates to the standard reference on NZ Challenge Coins.

Hamish MacMaster FRNSNZ



Hamish was born in 1961 in Christchurch, where he developed an early and passionate interest in coins and medals.

Hamish has been a member of the Royal Numismatic Society of NZ for over twenty-five years, serving as its Assistant Secretary (2003) and Secretary (2009-2013), and is currently a Vice President (2014-).

In addition to regular articles for the Society's Journal, he has written, in collaboration with Martin Purdy, the 2009 Catalogue of New Zealand Commemorative Medals 1941-2007, and its updated and expanded 2nd edition in 2014; and the 2011 New Zealand Challenge Coins: A Catalogue, and its second edition in 2016.

In 2010 he became a Fellow of the Society.

Pursuing a diplomatic career in the Ministry of Foreign Affairs and Trade, Hamish served as New Zealand's Ambassador to the Islamic Republic of Iran accredited also to Afghanistan and Pakistan (2004-2009) and was subsequently Ambassador to the Kingdom of Saudi Arabia (2015), resident in Riyadh and also accredited to Bahrain, Kuwait, and Oman. In 2016 his list of (non-resident) accreditations was expanded when he was appointed as New Zealand's first ever Ambassador to the Republic of Yemen. Hamish returned from serving again as Ambassador to Iran in 2021.



Join the Royal Numismatic Society of New Zealand

You are warmly invited to join the Royal Numismatic Society of New Zealand. The Society has operated since 1931 to promote all aspects of numismatics in New Zealand, including the study and collecting of coins, tokens, banknotes, and medals.

The Society offers you all this:

- A high-quality printed Journal with research and articles for the permanent record, usually published once a year with the occasional bonus issue
- Two information-packed Newsletters each year, normally in May and September
- Periodic postal auctions, Society Conventions, fairs, and promotions
- Access to the members' part of the Society web site
- Meetings where you can learn more, trade with fellow collectors and enjoy your interests with fellow enthusiasts. Normal monthly meetings are held at the Wellington Club, 88 The Terrace, Wellington, at 7:30 pm on the last Wednesday of the month. Check venues first as occasional meetings are held at other locations. Meetings are open to members via Zoom.
- The opportunity to join with an extensive membership base to advance collectors' interests.
- Participation in our Facebook community: <http://tinyurl.com/pe529bo>
- Access to our comprehensive library of numismatic material

Current **2024** subscription rates:

Standard Membership: **\$ 35.00**
Junior (Under 18): **\$ 17.50**
Australia: AUD **\$ 35.00**
Rest of World: USD **\$ 35.00**
(Less \$5 / \$2.50 for prompt payment)
Digital Subscription: NZ / AU / US **\$ 25**

Write or email today:

Royal Numismatic Society of New Zealand Inc.
P O Box 2023
WELLINGTON 6140

E-mail: secretary@RNSNZ.org.nz

Write or email today or join at www.RNSNZ.org.nz



[1897/18A]

ISBN 978-1-991108-60-9

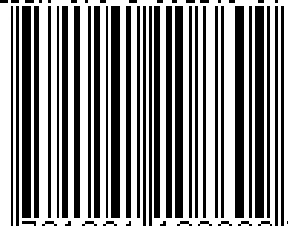

9 781991 108609 >